

## PIPELINE CONNECTORS UniAdca CX 402 ( Duplex design DN 25 - DN 40 )

### DESCRIPTION

The UniAdca CX series pipe connectors are used in steam systems where a simplified and economical maintenance program of steam is desired.

Typical installations are drip service on steam lines, tracing and small process equipment.

Two bolt flange connector permits trap replacement in minutes without disturbing piping.

The CX connector fits all UniAdca steam traps.

Connections are female screwed or flanged.

### MAIN FEATURES

Remains in-line permanently making replacing of new traps easier and quicker.

UniAdca steam traps can swivel 360° allowing any pipe orientation during installation.

The universal flange allows the trap to be positioned in the correct position, regardless of pipeline configuration.

Built-in strainer.

**OPTIONS:** Socket weld and ANSI flanged connections.

**USE:** Saturated and superheated steam.

**AVAILABLE**

**MODELS:** CX402S - Forged steel construction  
CX402SS - Stainless steel construction

**SIZES:** DN 1" and 1 1/2" - DN 25 and 40.

**CONNECTIONS:** Female screwed ISO 7/1 Rp (BS21).  
Flanged DIN or ANSI .

**INSTALLATION:** Can be installed in any position according to the type of UniAdca steam trap to be used.  
See IMI installation and maintenance instructions.

PMA:Max.allowable pressure 80 bar

TMA:Max.allowable temperature 425 °C

PMO:Max.operating pressure 32 bar

TMO:Max.operating temperature 400 °C

How to order: i.e. CX402S DN 25 DIN .

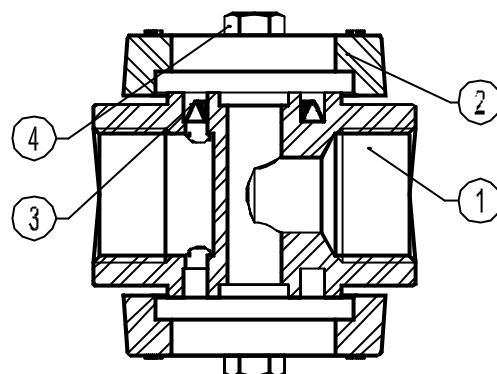

### MATERIALS:

POS.NR.	DESIGNATION	MATERIAL
1	BODY	C22.8 or AISI 316
2	FLANGE	C22.8 or AISI 316
3 *	STRAINER	AISI 304
4 *	BOLTS	STAINLESS STEEL

\* AVAILABLE SPARE PARTS

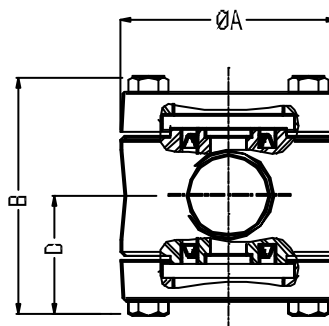
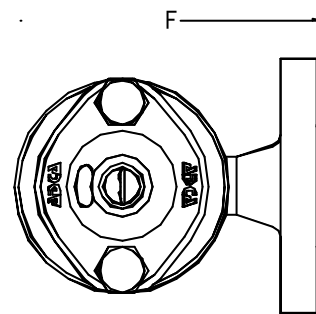

### DIMENSIONS (mm)

SIZE	Screwed Ends				DIN Flanges	
	A	B	D	WEIGHT	F	WEIGHT
DN				Kg		Kg
1"	80	100	50	2,2	160	4,8
1 1/2"	110	112	56	3,8	230	8,4