

FLOAT AND THERMOSTATIC STEAM TRAPS FLT 22 SS (Fabricated Stainless Steel) (1 1/2" - 2")

DESCRIPTION

FLT 22 SS float and thermostatic (integral air vent) steam traps series are designed for all types of low and medium pressure steam heating and process equipment.

Connections are female screwed or flanged for horizontal or vertical installation.

MAIN FEATURES

Modulating discharge.

Discharges condensate at steam temperature.

Unaffected by sudden or wide load and pressure changes.

Excellent air discharge (by thermostatic air vent).

OPTIONS: Equalizing plug, venting connection and drain plug (or blow-off valve on cover).

USE: Saturated and superheated steam.

AVAILABLE

MODELS: FLT 22-4.5 - FLT 22-10 - FLT 22-14 - FLT 22-21

SIZES: 1 1/2", 2" - DN40, DN50.

CONNECTIONS: Female screwed ISO 7/1 Rp (BS21)

Flanged DIN. Special flanges upon request.

INSTALLATION: Horizontal or vertical installation.

Flow from right to left FLT22 (R-L) or left to right (L-R).

PMA: Max. allowable pressure 25 bar

TMA: Max. allowable temperature 400 °C

PMO: Max. operating pressure 21 bar

TMO: Max. operating temperature 250 °C

How to order: i.e. FLT22 SS-10 DN 40 DIN

DIMENSIONS (mm)

SIZE	SCREWED ENDS				DIN FLANGES			
	A	B	C	WEIGHT	D	E	F	WEIGHT
DN	Kg				Kg			
1 1/2"	285	285	110	29,8	355	315	320	35,5
2"	295	285	110	30,3	355	360	320	36

All dimensions and weights are approximate.

Please consult factory for certified dimensions.

FLOW RATE CAPACITY IN Kg/h

MODEL	SIZE	DIFFERENTIAL PRESSURE (bar)											
		0,5	0,7	1	1,5	2	4,5	7	10	12	14	16	21
FLT22-4,5	1 1/2"	2400	2800	3400	3900	4500	7300						
FLT22- 10	1 1/2"	1500	1750	2000	2600	3000	4000	5400	6200				
FLT22- 14	1 1/2"	950	1100	1300	1600	1800	2600	3250	3900	4210	4950		
FLT22- 21	1 1/2"	950	1100	1300	1600	1800	2600	3250	3900	4210	4950	5000	5600
FLT22-4,5	2"	7550	9050	11000	14000	15500	22500						
FLT22- 10	2"	3900	4450	5000	6100	7100	10000	13750	16000				
FLT22- 14	2"	1900	2300	2700	3100	3600	5000	6900	8100	9000	9800		
FLT22- 21	2"	1900	2300	2700	3100	3600	5000	6900	8100	9000	9800	10000	12050

Recommended safety factor : continuous 1.2 - 1.5 ; discontinuous flow 2 - 3 .

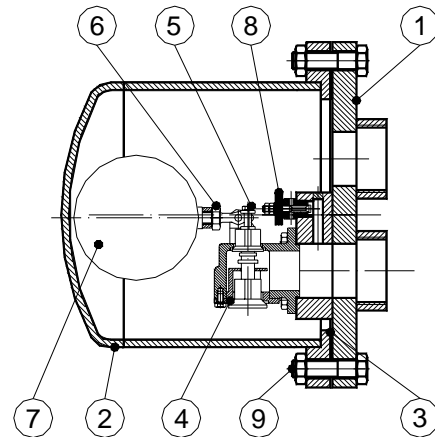
MATERIALS:

POS.NR.	DESIGNATION	MATERIAL
1	BODY	ST. STEEL
2	COVER	ST. STEEL
3 *	GASKET	NON ASBESTOS
4 *	SEAT	AISI 410
5 *	VALVE	AISI 410
6 *	LEVER	AISI 304
7 *	FLOAT	AISI 304
8 *	AIR VENT	STAINLESS STEEL
9	BOLTS	ST. STEEL

* AVAILABLE SPARE PARTS

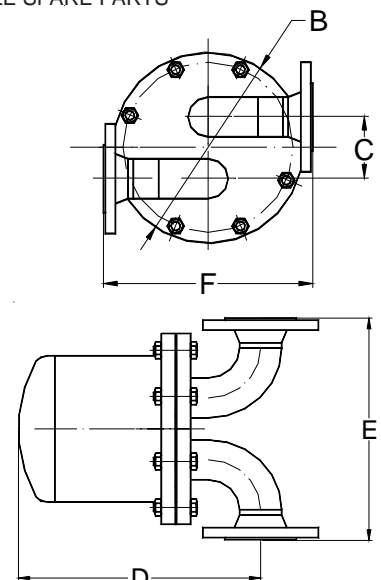
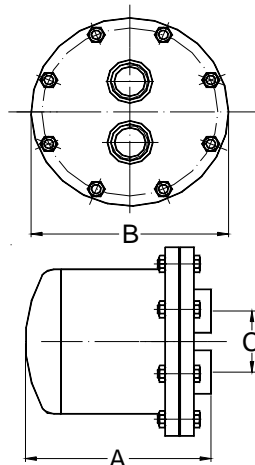

Max. differential pressure
 FLT 22-4.5 - 4.5 bar
 FLT 22-10 - 10 bar
 FLT 22-14 - 14 bar
 FLT 22-21 - 21 bar